

Part Number : 44080

EXTENDED FORWARD CONTROL KIT FOR LATE 1987 THRU 1989 FXST,FXSTC, FXSTS

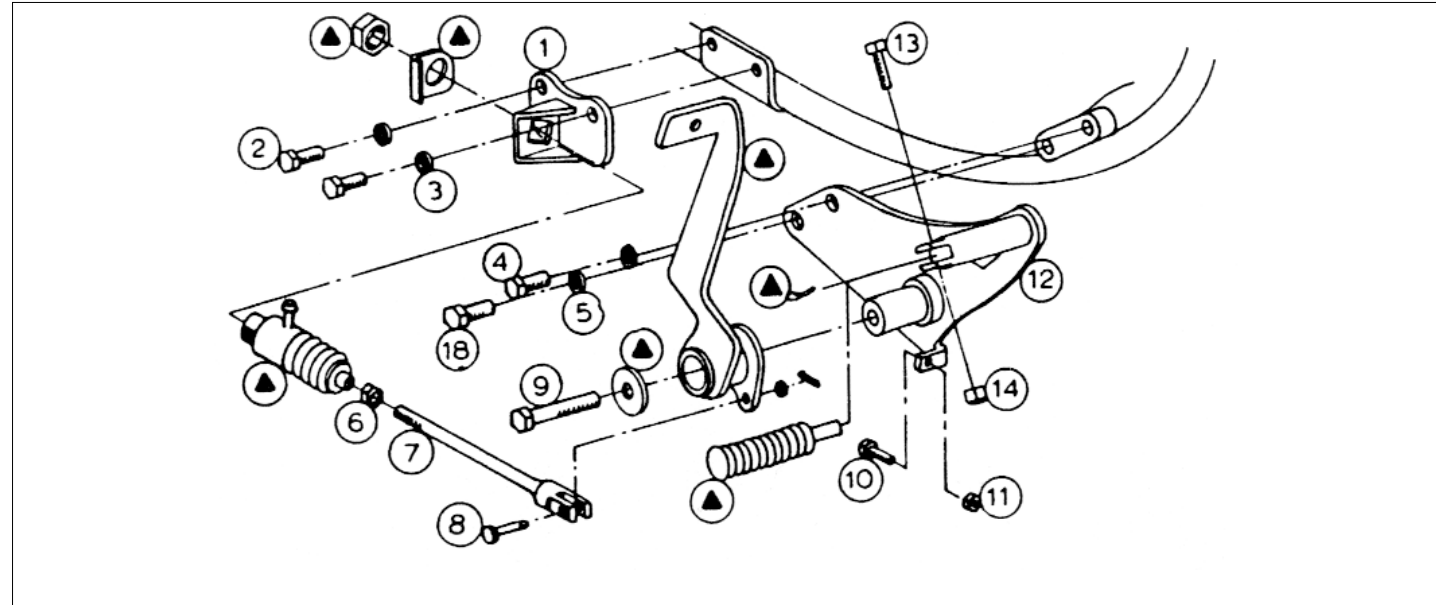

Brake Side Assembly

1. Remove exhaust system
2. Remove brake lever clevis and loosen brake jam nut. Unscrew brake rod from master cylinder.
3. Remove rear brake line (not necessary on 1989 models).
4. Remove cylinder mounting nut and lock plate being careful not to damage reservoir line nipple (not necessary on 1989 models).
5. Unbolt brake lever from bracket. Unbolt bracket from frame mounting points.
6. Bolt new master cylinder bracket (1) to original mounting position, using original mounting nut and lock plate, secure master cylinder to its new bracket (not necessary on 1989 models).
7. Re-install rear brake line as original positioned.
8. Install new brake lever bracket using two bolts (4) and (18), and lock washers (5). Brake lever stop bolt (10) and jam nut (11) should be installed at this time.
9. Brake lever can now be secured to bracket (12) using bolt (9) and original large washer. Transfer foot peg from old bracket using new bolt (13) and nut (14). Stop bolt (10) can now be adjusted to proper brake lever position. Tighten stop bolt jam nut (11) securely.
10. Thread new jam nut (6) onto new brake rod (7) and screw into master cylinder until clevis holes in brake rod and brake lever are aligned. Install new clevis on assembly (8) and tighten jam securely.
11. Bleed brake system thoroughly using D.O.T. 5 brake fluid
12. Re-install exhaust system.

Note: Use blue Loctite on the first three threads of all hardware.

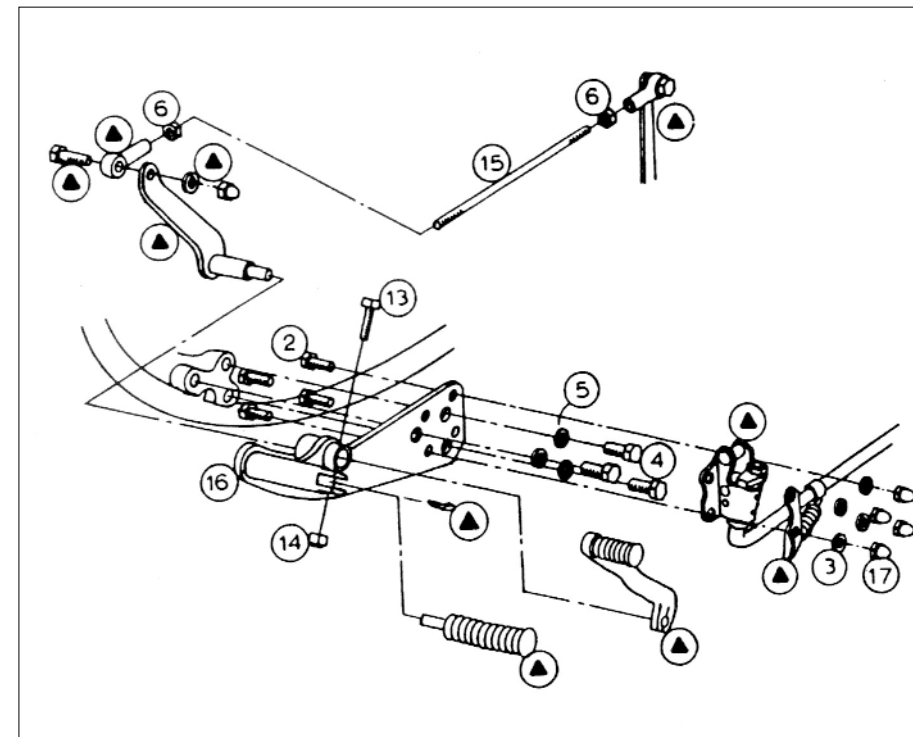

Shift assembly.

1. Block motorcycle securely so kickstand assembly can be removed.
2. Remove kickstand and bracket assembly.
3. Loosen jam nuts on shift lever clevis and transmission shift lever clevis. Remove clevis from shift lever and unscrew shift rod from both clevises.
4. Remove shift lever bracket from motorcycle.
5. Transfer original shift lever onto extended shift lever bracket (16). Original foot peg may also be transferred at this time using bolt (13) and nut (14).
6. Mount extended shift lever bracket (16) onto motorcycle using three bolts (4) and lock washers (5).
7. Thread two jam nuts (6) onto new shift rod (15) and install rod into transmission lever clevis. Screw original shift lever clevis onto other end and using original bolt and acorn nut, adjust and fasten on-to shift lever so that shift lever is as near original angle as possible.
8. Install kickstand and bracket in reverse order of disassembly using bolts (18) lock washer (3) and acorn nuts (17).
9. Arrange foot lever on-to shift lever shaft at angle best suited for your individual operation.

(Symbol (³) denotes original equipment)

Nmbr	Qty	Description
1	1	Bracket Master Cylinder
2	6	Bolt 5/16"-18 x 1" hex head
3	6	Lock washer 5/16"
4	4	Bolt 3/8"-16 x 1" hex head grade 8
5	5	Lock washer 3/8"
6	3	Nut 5/16"
7	1	Brake Rod
8	1	Clevis pin assembly
9	1	Bolt 3/8"-16 x 3" hex head grade 5
10	1	Bolt 1/4"-28 x 1" hex head
11	1	Nut 1/4"-28
12	1	Bracket brake lever
13	2	Bolt 3/8"-16 x 1 1/2" hex head
14	2	Nut 3/8"-16 Lock type
15	1	Shift rod
16	1	Bracket shift lever
17	4	Acorn nut 5/16"-18
18	1	Bolt 3/8"-16 x .88 hex head grade 8